

Motor connector

Pin No.	Name
A	—
B	—
C	—
D	U
E	V
F	W
G	PE
H	PE
I	—

Encoder connector

Pin No.	Signal	Pin No.	Signal
1	Vbat	6	—
2	GND (bat)	7	—
3	—	8	SD+
4	Vcc	9	SD-
5	GND (Vcc)	10	FG

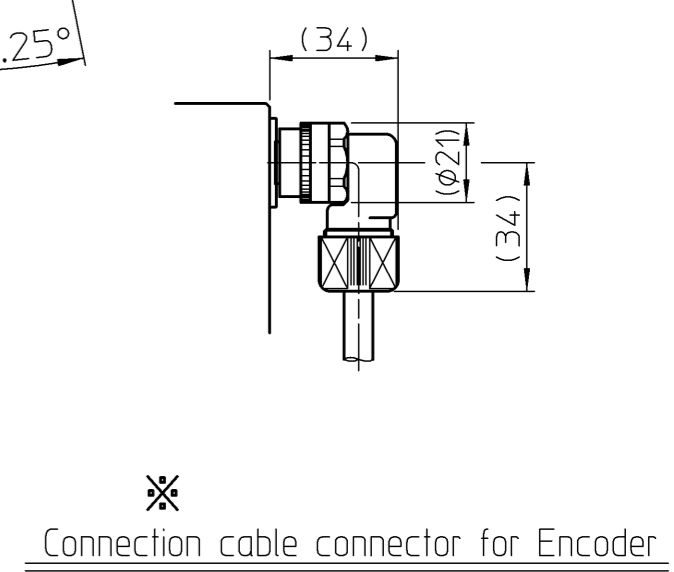
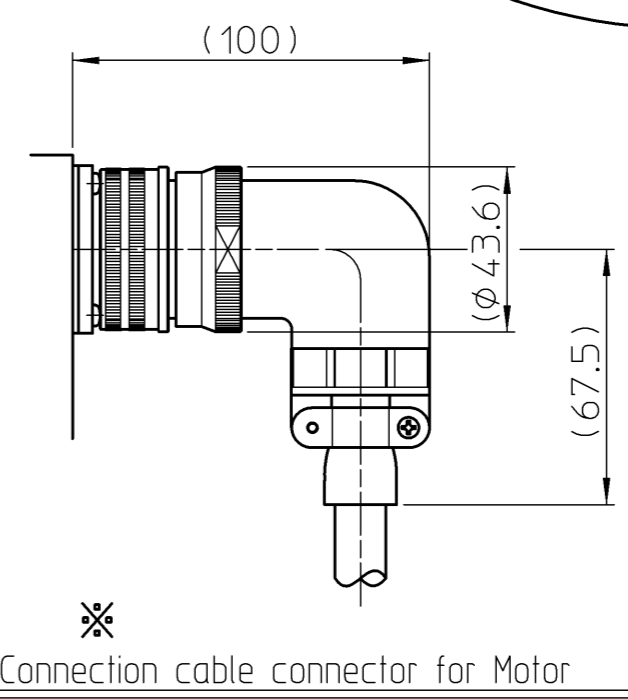
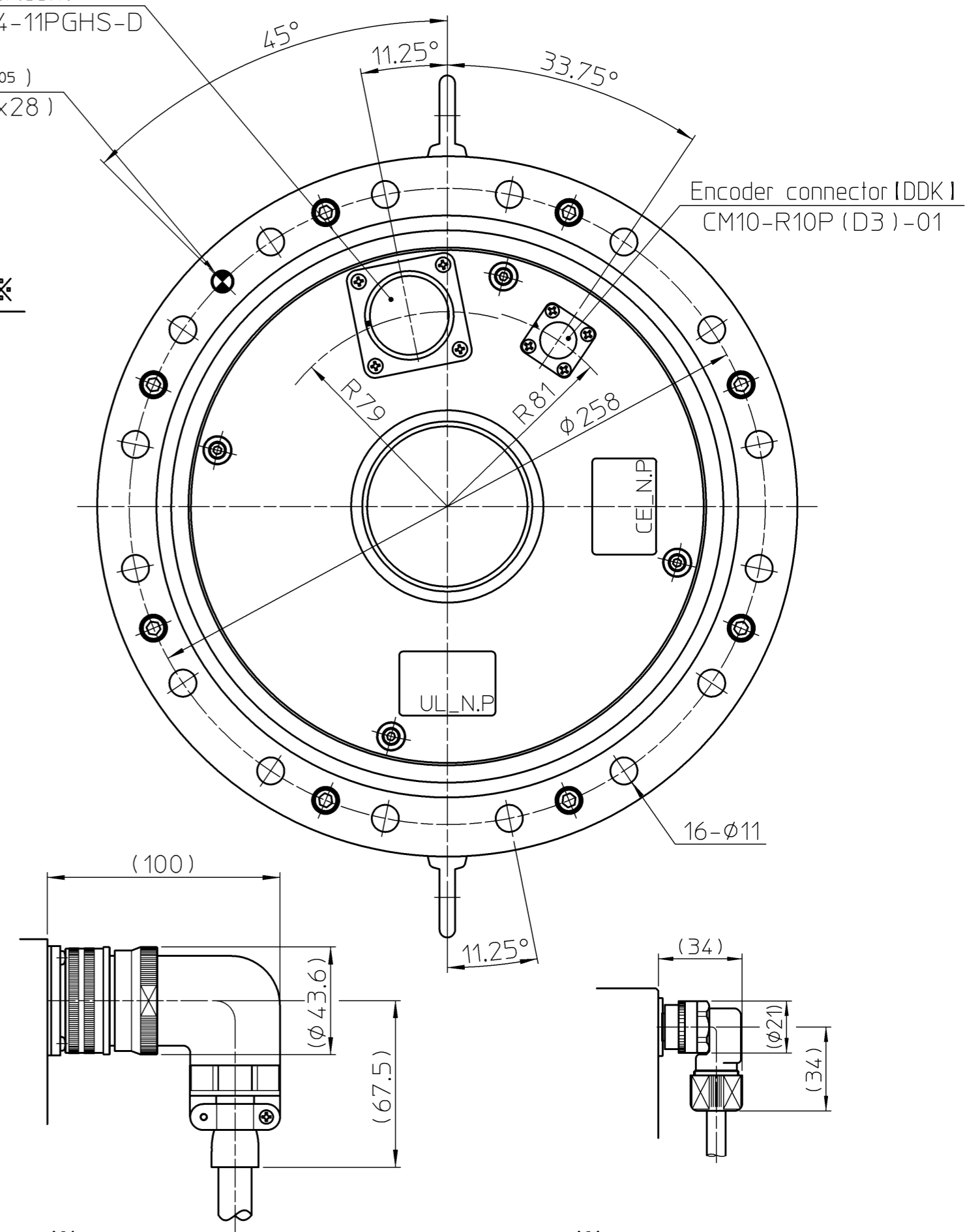
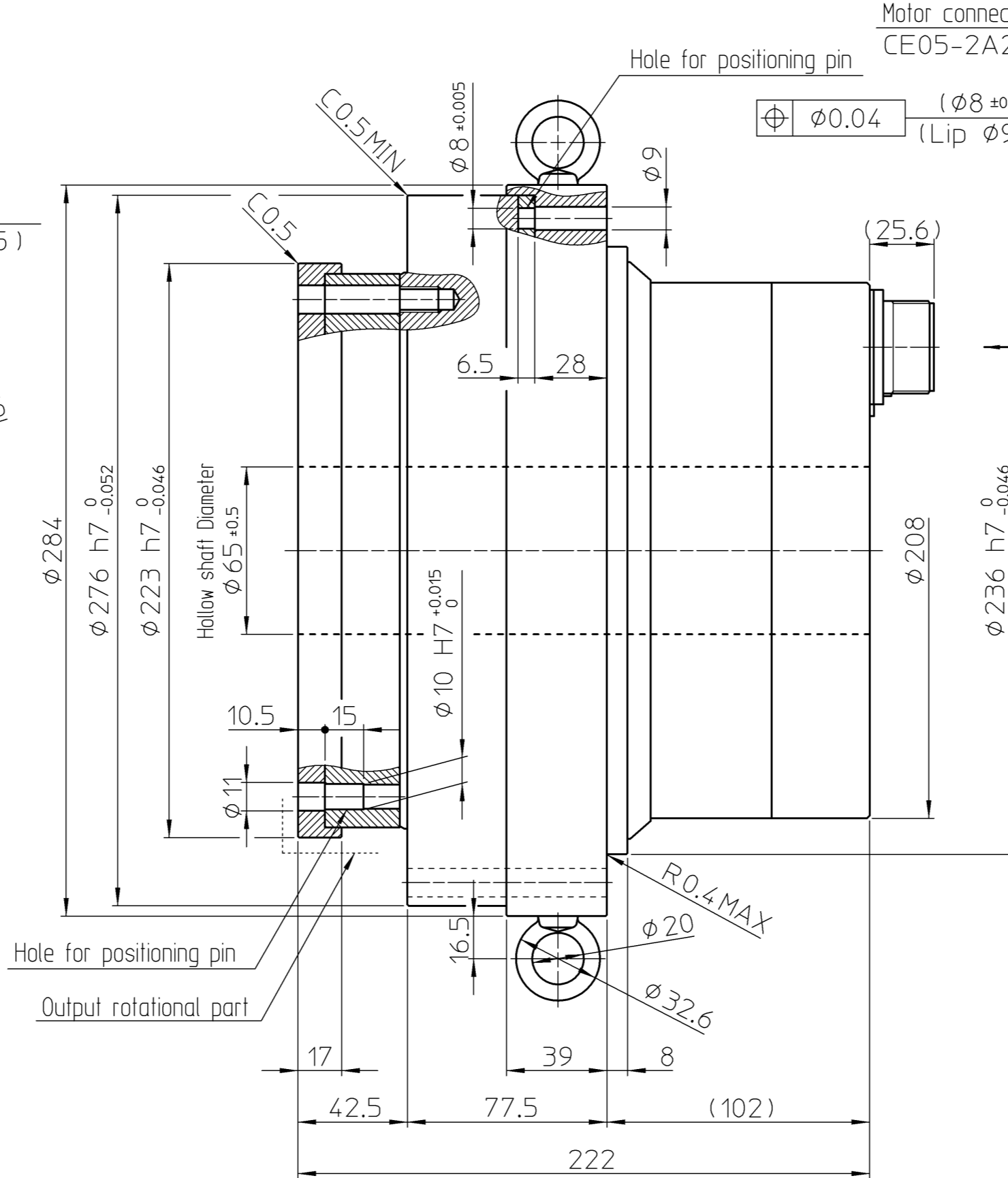
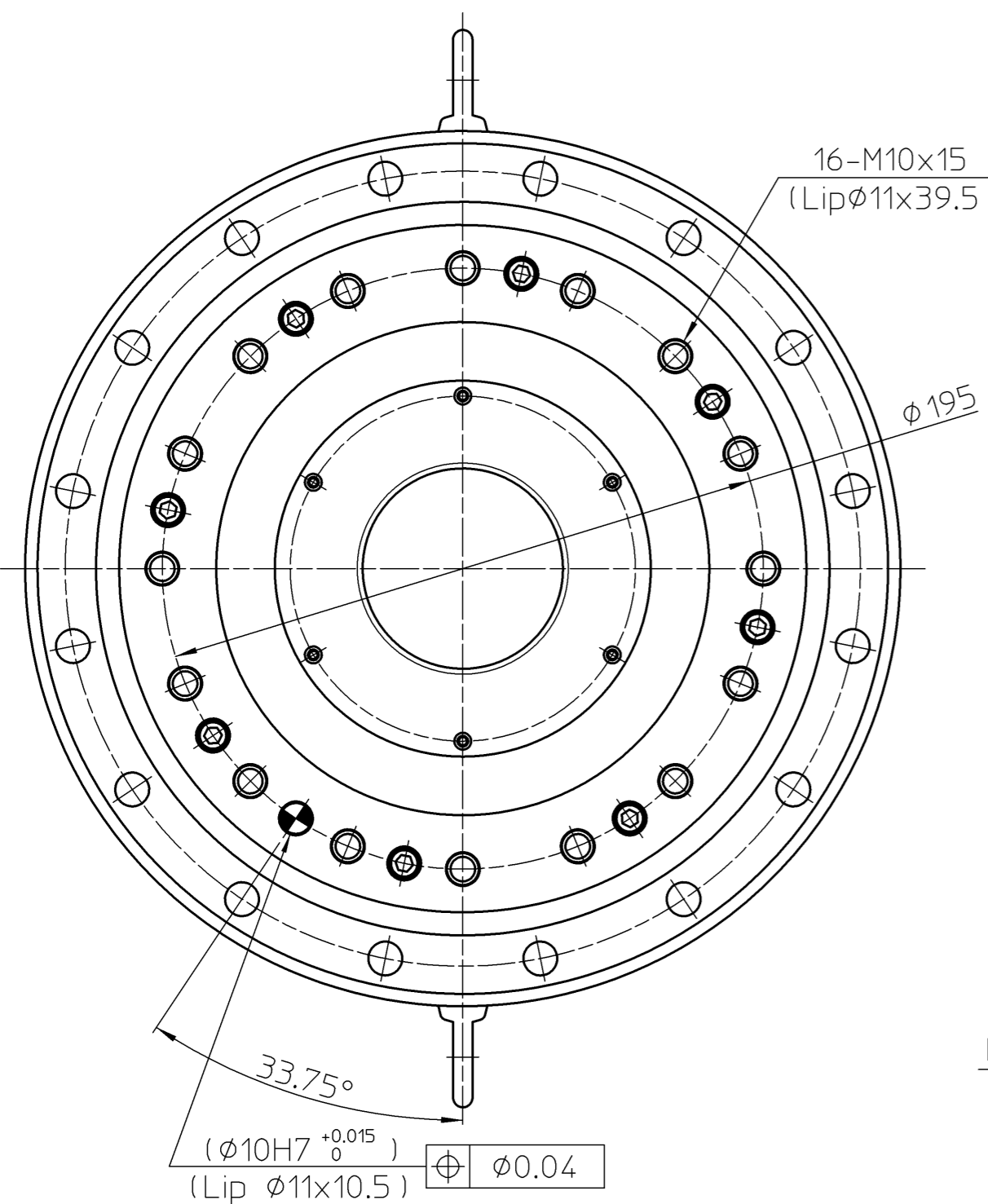

PROPRIETORSHIP
This drawing (document) is the **PROPERTY** of Harmonic Drive Systems, Inc. and shall not be traced, otherwise copied or used for purposes other than agreed upon, nor communicated to any third party without written permission of Harmonic Drive Systems, Inc.

CUSTOMER DRAWING NO.

訂正 REV	仕様 SPEC	来歴 DESCRIPTION	備考 REMARKS				
0	0.5	6	30	120	315	1000	
1	6	30	120	315	1000	2000	特記無き角はCO.2以下、寸みの丸みはRO.4以下
							無記号表面アラス
							SURFACES MARKED EXCEPT AS NOTED

設計 DESIGN	校閲 VRFD	承認 APPD	DATE	タイトル TITLE
T.Hirabayashi	N.NAKAMURA	T.Yamagishi	Aug- 5-10	SHA65A121SG-A21A200-10S17bA-C
				製品名 ARTICLE
				OUTLINE DRAWING
				図番 DWG No
				B2T0168